



Fire-LITE[®] Alarms
INCORPORATED

July 8, 1998

F-400

XAL-53 Explosion-Proof Pull Station

Section: Conventional Initiating Devices

APPLICATIONS

KILLARK[®] fire alarm stations are suitable for:

- Hazardous areas due to the presence of flammable gases or vapors, combustible dusts or easily ignitable fibers or flyings.
- Installation at petroleum refineries, chemical and petrochemical plants, storage areas, and other processing facilities where hazardous substances are handled and stored.
- Areas where emergency control of fire alarm or signal circuits is required.

FEATURES

- Enclosure is made of copper-free aluminum alloy.
- Conduit openings are 3/4" (19.05 mm) NPT feed-through.
- Red, textured powder epoxy paint finish is standard on box and cover and provides high visibility for alarm station.
- Universal (1) normally open and (1) normally closed contact furnished standard.
- Bilingual nameplates included per CSA requirement.
- Internal ground screw is standard.
- Wiring range is #12 AWG through #24 AWG, solid or stranded.

OPERATION

The alarm station is activated by lifting the front cover and pulling down ring. This quick, easy-to-use two-step process prevents unintentional operation. Operator is reset by depressing shaft and returning plate to original position.

HAZARDOUS AREA CLASSIFICATIONS

- Class I, Division 1 and 2, Group C and D.
- Class II, Division 1 and 2, Group E, F, and G.
- Class III, Hazardous Locations.
- NEMA 7CD, 9EFG.

CONTACT BLOCK RATING ►

KILLARK[®] is a registered trademark of Hubbell[®].

A C						D C		
Volts	Make Amperes	VA	Break Amperes	VA	Continuous Carrying Amperes	Volts	Make Break	Continuous Carrying Amperes
120	60	7200	6.0	720	10	125	1.10	10
240	30	7200	3.0	720	10	250	0.55	10
480	15	7200	1.5	720	10	600	0.20	10
600	12	7200	1.2	720	10			



E50498



California State Fire Marshal
7150-1439:100



CE69

CSA

LR31085



XAL-53
Pull Ring

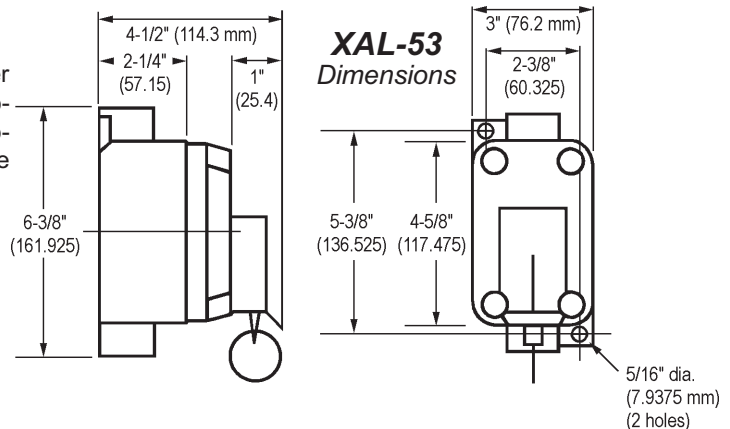

This document is not intended to be used for installation purposes. We try to keep our product information up-to-date and accurate. We cannot cover all specific applications or anticipate all requirements. All specifications are subject to change without notice. For more information, contact Fire-Lite. Phone: (203) 484-7161 FAX: (203) 484-7118



12 Clintonville Road, Northford, Connecticut 06472

ISO-9001
Engineering and Manufacturing
Quality System Certified to
International Standard ISO-9001



Made in the U.S.A.

OPERATIONAL DATA

This enclosure is made of cast, copper-free aluminum alloy. It is suitable for: Class I, Groups C and D; Class II, Groups E, F, and G; and Class III hazardous locations. All installations must comply with applicable local and/or National Electrical Code.

CAUTION!

During installation, DO NOT use looped wire under terminals. Break wire run to provide supervision of connections.

Like all electromechanical devices, these control stations require occasional maintenance. Parts may wear out or become defective due to adverse environmental conditions. See *Maintenance Data* below.

MAINTENANCE DATA

CAUTION!

Disconnect this device from the supplying circuit before removing the cover.

- 1) To prevent corrosion, lubricant should be occasionally applied, as follows:
 - Killark "LUBG" lubricant **to box/cover flanges.**
 - Dow Corning Molykote 33 Grease, light consistency, **to operator shaft.**
- 2) Keep all flanges clean and free of scratches.
- 3) Some internal service parts are available. Consult the Killark factory for parts breakdowns.

CONTACT ARRANGEMENT

